

# Aku Cinta **INDONESIA**

Dede Abdurrohman  
Pandu Dharma

Hak Cipta © 2018 pada Kementerian Pendidikan dan Kebudayaan  
Dilindungi Undang-Undang

Katalog Dalam Terbitan (KDT)

Indonesia. Kementerian Pendidikan dan Kebudayaan.

Aku Cinta Indonesia: Buku Aktivitas/Kementerian Pendidikan dan Kebudayaan.

—Jakarta: Kementerian Pendidikan dan Kebudayaan, 2018.

iv, 28 hlm. : ilus.; 21 x 29,7 cm.

Model Buku PAUD

untuk anak usia 5-6 tahun

ISBN: 978-602-244-161-8

Penulis : Dede Abdurrohman  
Ilustrator : Pandu Dharma  
Penata Letak : Muhsinul Fajri  
Penelaah : Rennie Kusnaeni, M.Pd.  
Dr. Soraya, M.Hum.  
Ratih Zulhaqqi, M.Psi.  
Penyelia : Pusat Kurikulum dan Perbukuan, Balitbang, Kemendikbud.  
Kontributor Naskah : Diah Harianti, Nanik Suwaryani, Anggraeni, Yuke Indrati.

Cetakan ke-1, 2018

Disusun dengan huruf Andika New Basic 18 pt.

# Kata Pengantar

Buku aktivitas “Aku Cinta Indonesia” ini merupakan salah satu buku model PAUD pada tahap penjenjangan membaca awal untuk anak usia 5-6 tahun yang dikembangkan Pusat Kurikulum dan Perbukuan untuk digunakan di satuan PAUD.

Model buku ini disusun untuk membantu orangtua/pendidik/orang dewasa dalam menanamkan kecintaan pada Indonesia melalui berbagai aktivitas kreatif yang ditunjang dengan sejumlah media yang disesuaikan dengan buku ini serta dapat dikembangkan lebih lanjut sesuai dengan karakteristik satuan pendidikan dan daerah setempat. Buku ini dapat dibacakan oleh orangtua/pendidik/orang dewasa untuk menumbuhkan rasa ingin tahu anak sehingga nantinya muncul minat baca pada anak sejak dini. Orangtua/pendidik/orang dewasa dapat mengembangkan materi dalam buku ini sesuai kondisi lingkungan anak dan kebudayaan daerah setempat.

Ucapan terima kasih penulis sampaikan kepada semua pihak yang terlibat dalam proses penyelesaian buku ini. Semoga model buku ini dapat menjadi bahan referensi penulis lain untuk mengembangkan model buku PAUD sejenis dan dalam mengembangkan kegiatan pembelajaran di PAUD.

Jakarta, November 2018

Penulis

Dede Abdurohman



# Daftar Isi

Kata Pengantar .....	iii
Daftar Isi .....	iv
Aku Cinta Indonesia .....	1
Memperkenalkan Diri .....	2
Berperilaku Baik .....	3
Gambar Bendera Indonesia .....	4
Menyusun Potongan Gambar .....	5
Membuat Bendera Merah Putih .....	6
Mencari Perbedaan Gambar .....	8
Membuat Alat Musik .....	10
Gambar dengan Tulisan.....	12
Menghitung Gambar .....	13
Melengkapi Angka.....	14
Menempel Lidi .....	15
Menghias Gambar Padi dan Kapas .....	16
Membuat Rumah Honai .....	18
Menghias Monas.....	20
Kecil-Besar.....	22
Menunjukkan Jalan .....	23
Tips Menjadi Anak Indonesia.....	25
Pelaku Perbukuan .....	26
Lembar Gunting Tempel .....	27

# Aku Cinta INDONESIA





## Memperkenalkan Diri

- ✎ Boni dan Fida anak Indonesia.
- ✎ Anak-anak maju ke depan kelas satu per satu.
- ✎ Anak-anak memperkenalkan diri.

Aku Boni.  
Aku tinggal di Jakarta.  
Aku anak Indonesia.



Aku Fida.  
Aku tinggal di Padang.  
Aku anak Indonesia.





## Berperilaku Baik

- Amati gambar di bawah.
- Anak Indonesia selalu berperilaku baik.
- Ceritakan perilaku baik yang ada pada gambar ini.

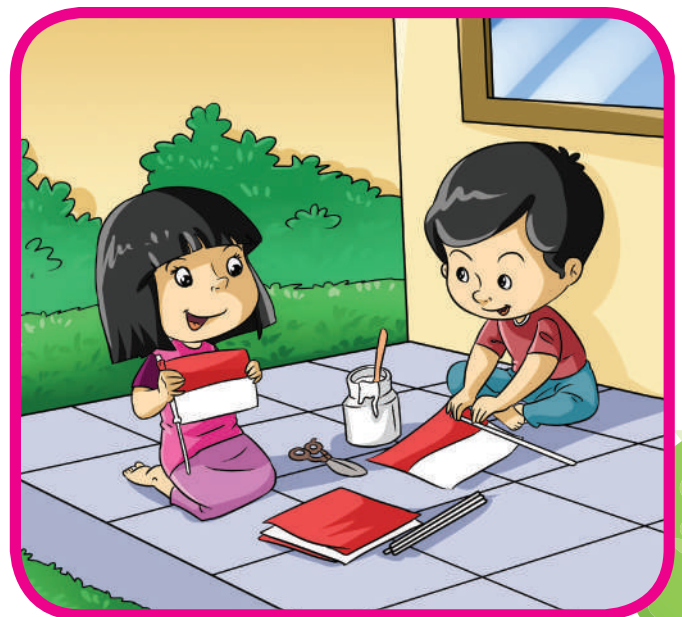



## Gambar Bendera Indonesia

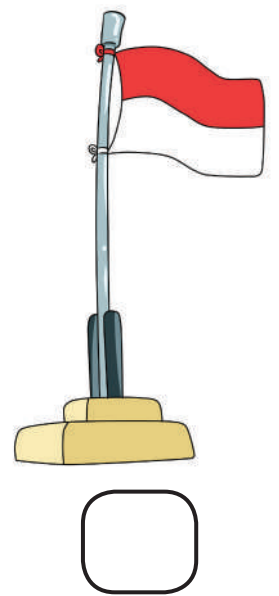
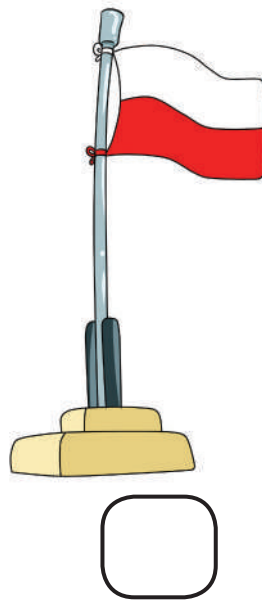
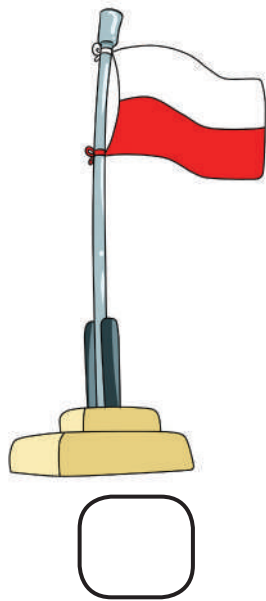
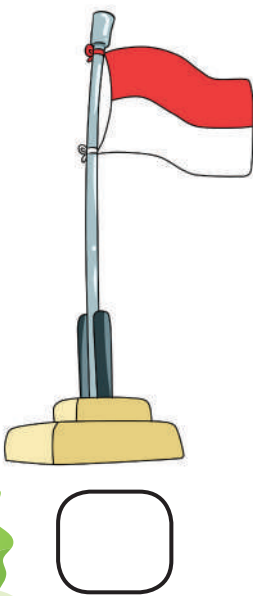
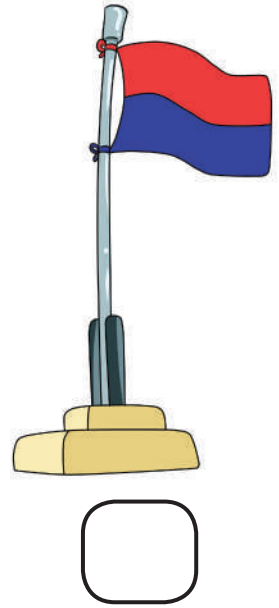
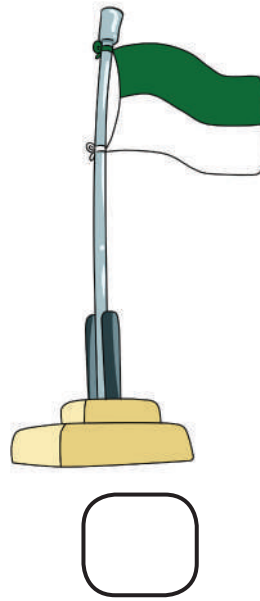
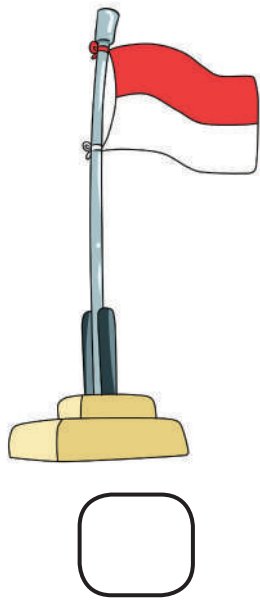
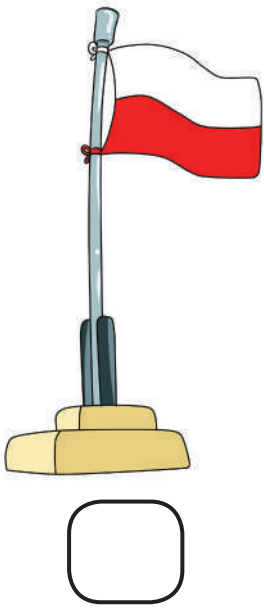

- Cari gambar Bendera Indonesia.
- Beri tanda ✓ di kotak yang tersedia.







## Menyusun Potongan Gambar

-  Amati gambar utuh yang ada di sebelah kanan.
-  Gunting potongan gambar puzzle pada halaman 29.
-  Tempelkan potongan gambar hingga utuh di tempat yang tersedia.

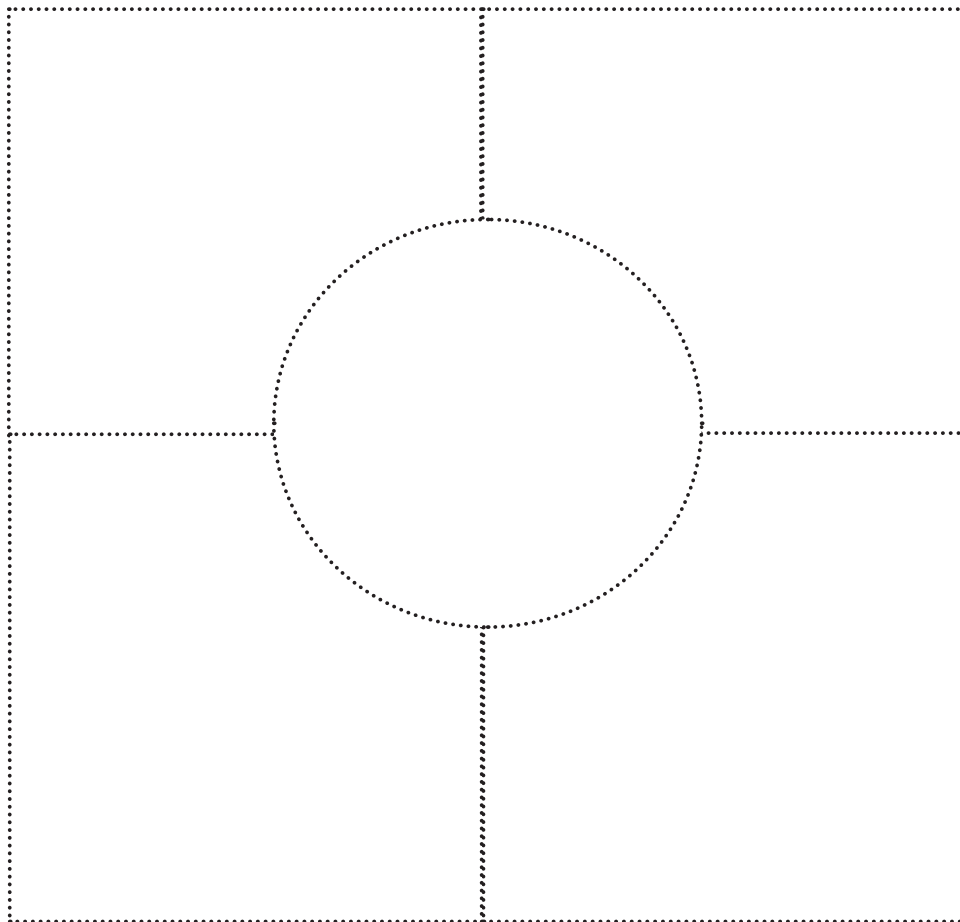



## Membuat Bendera Merah Putih

- ✎ Mari membuat Bendera Merah Putih.
- ✎ Kerjakan dengan sabar supaya bagus.

### Bahan dan Alat:

- Kertas minyak warna merah dan putih
- Lidi atau sedotan
- Gunting
- Lem

### Cara Membuat:

1. Gunting kertas minyak bentuk persegi panjang.





2. Tempelkan pada lidi atau sedotan.



3. Ayo, kibarkan Bendera Merah Putih buatanmu.





## Mencari Perbedaan Gambar

- Amati dua gambar di bawah.
- Cari lima perbedaan pada gambar.
- Beri tanda **X** pada perbedaannya.

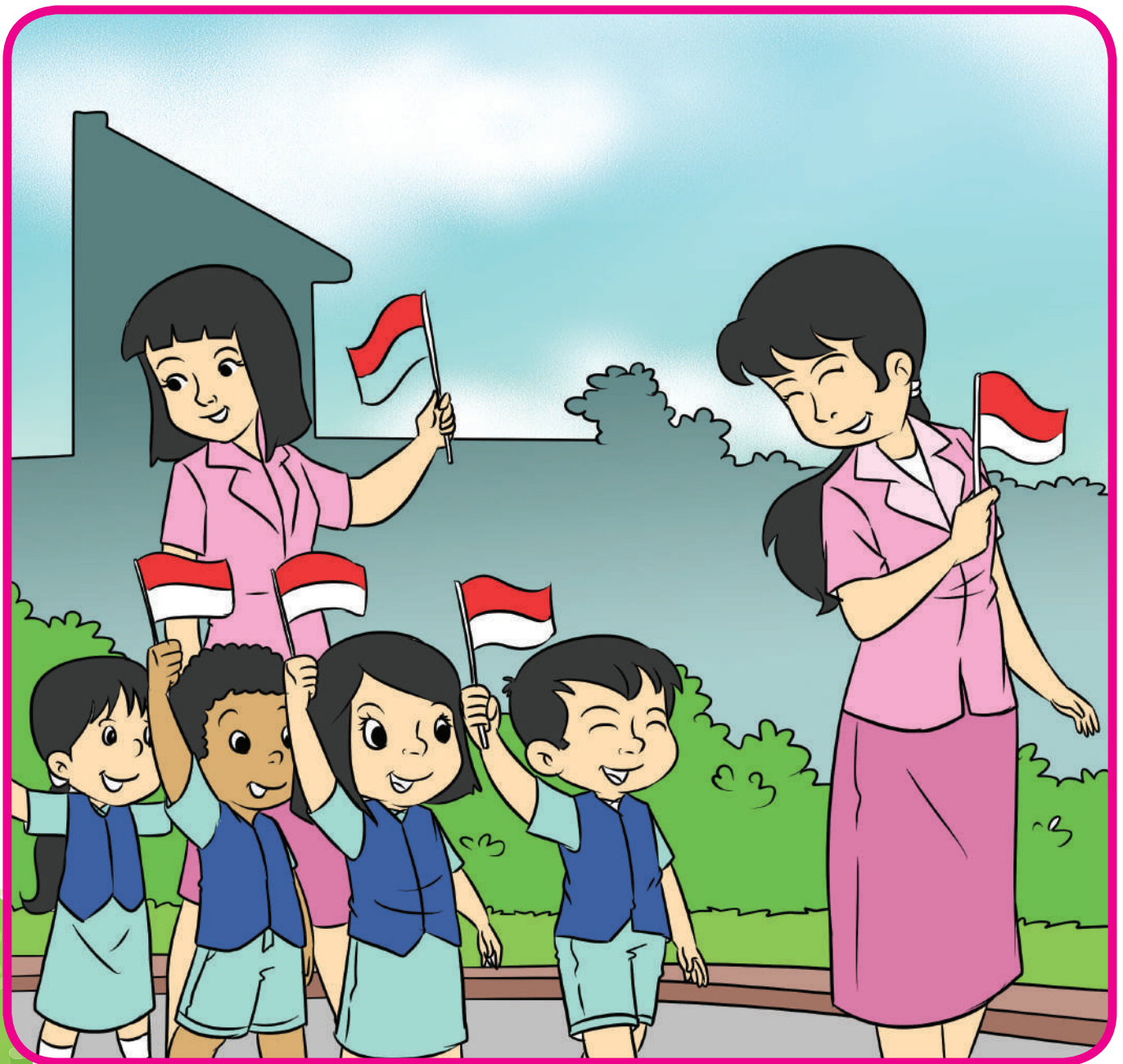





## Membuat Alat Musik

 Mari membuat alat musik.

### Bahan dan Alat:

- Botol plastik bekas
- Biji-bijian atau batu kerikil
- Kertas atau plastik
- Karet gelang
- Tutup botol minuman yang sudah dilubangi
- Lidi atau bambu kecil

### Cara Membuat:

1. Masukkan biji-bijian ke dalam botol plastik.
2. Tutup mulut botol dengan kertas atau plastik.
3. Ikat dengan karet.

### Cara Membuat:

1. Masukkan tutup botol minuman yang sudah dilubangi ke dalam lidi atau bambu.
2. Ikat ujung lidi dan bagian tengah lidi dengan karet.





- ✎ Mari memainkan alat musik buatanmu.
- ✎ Nyanyikan lagu Garuda Pancasila diiringi alat musikmu.



## Garuda Pancasila



Ciptaan: Sudharnoto

Garuda Pancasila  
Akulah pendukungmu  
Patriot proklamasi  
Sedia berkorban untukmu

Pancasila dasar negara  
Rakyat adil makmur sentosa  
Pribadi bangsaku  
Ayo maju ... maju  
Ayo maju ... maju  
ayo maju ... maju





## Gambar dengan Tulisan

- Lihat gambar dan tulisan di bawah.
- Hubungkan gambar dengan tulisannya.



Bintang



Rantai



Pohon Beringin



Kepala Banteng



Padi dan Kapas

Pohon  
Beringin

Rantai

Padi dan  
Kapas

Bintang

Kepala  
Banteng

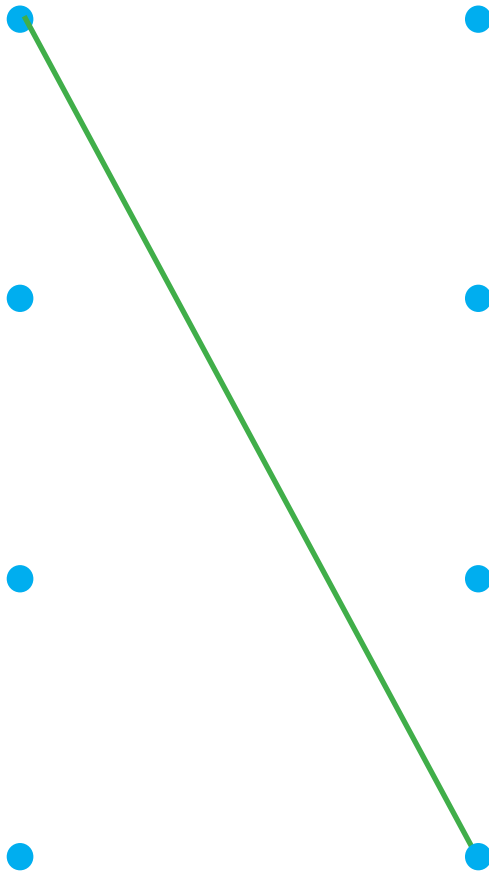





# Menghitung Gambar

- ✎ Hitung setiap kumpulan gambar.
- ✎ Tulis angkanya di dalam kotak.

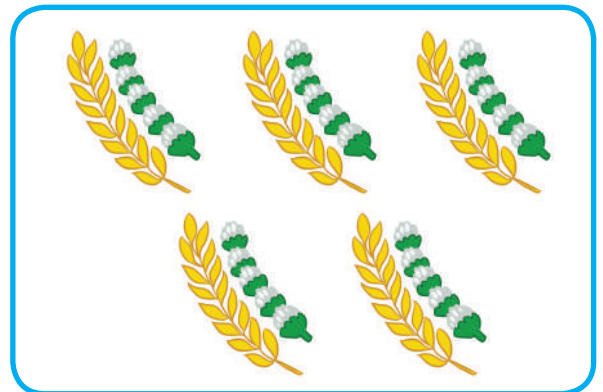
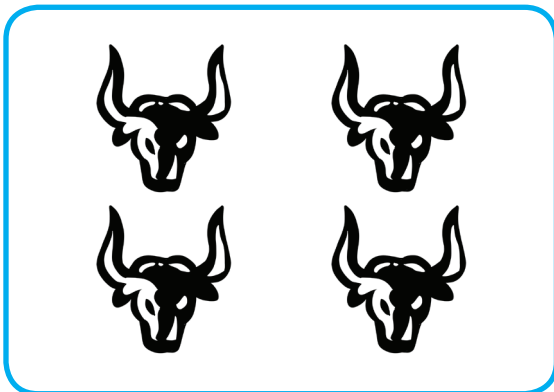
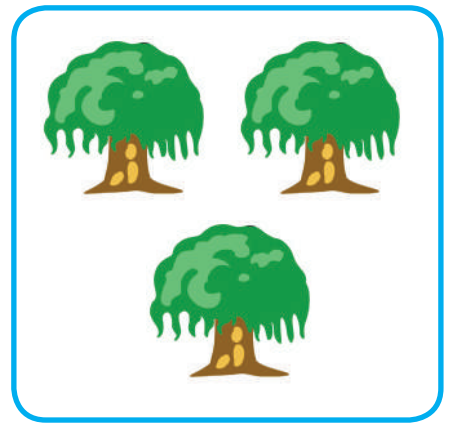
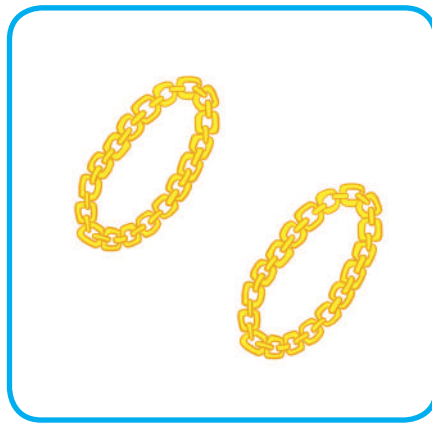



## Melengkapi Angka

- Lengkapi angka di bawah secara berurutan.
- Gunting gambar bintang pada halaman 29.
- Tempelkan di tempat yang sesuai.

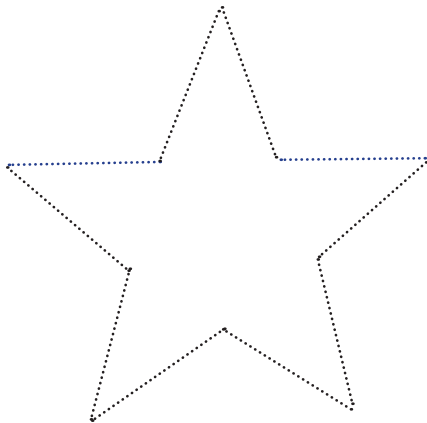
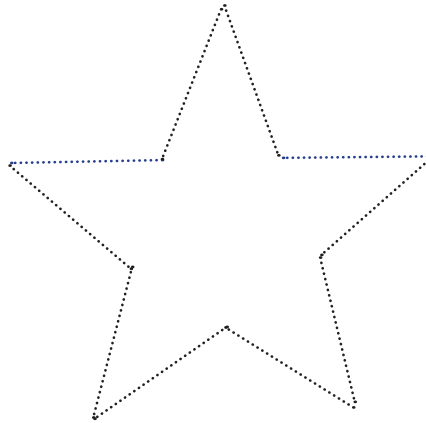



## Menempel Lidi

- ✏ Siapkan potongan lidi dan lem.
- ✏ Tempelkan potongan lidi pada garis bintang.

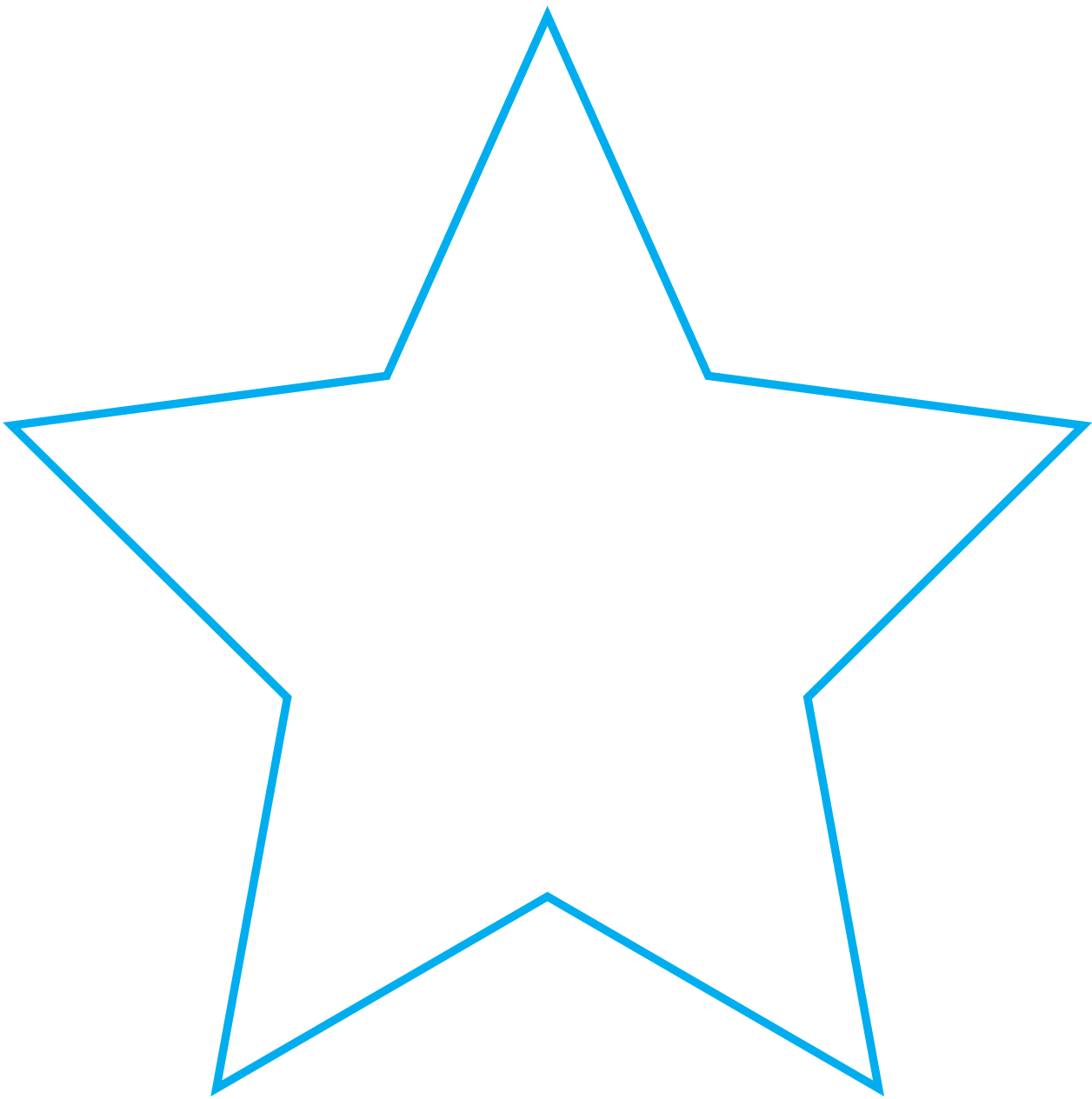



## Menghias Gambar Padi dan Kapas

- ✎ Mari menghias gambar padi dan kapas.
- ✎ Kerjakan dengan sabar supaya bagus.

### Bahan dan Alat:

- Kapas
- Daun pisang yang kering
- Pewarna makanan warna hijau
- Lem

### Cara Membuat:

1. Campur sebagian kapas dengan pewarna hijau.
2. Keringkan kapas yang dicampur pewarna.
3. Sobek-sobek daun pisang yang kering.
4. Tempelkan pada gambar padi.
5. Tempelkan kapas putih dan kapas hijau pada gambar kapas.





## Membuat Rumah Honai

- ✏ Rumah Honai adalah rumah adat Papua.
- ✏ Mari membuat rumah Honai dari barang bekas.

### Bahan dan Alat:

- Kardus bekas
- Kertas koran
- Kertas berwarna
- Gunting
- Lem

### Cara Membuat:

1. Guru mempersiapkan lembaran kardus bekas.
2. Gunting lembaran kardus berbentuk persegi panjang.
3. Gulung kardus tersebut dan lem kedua sisinya.

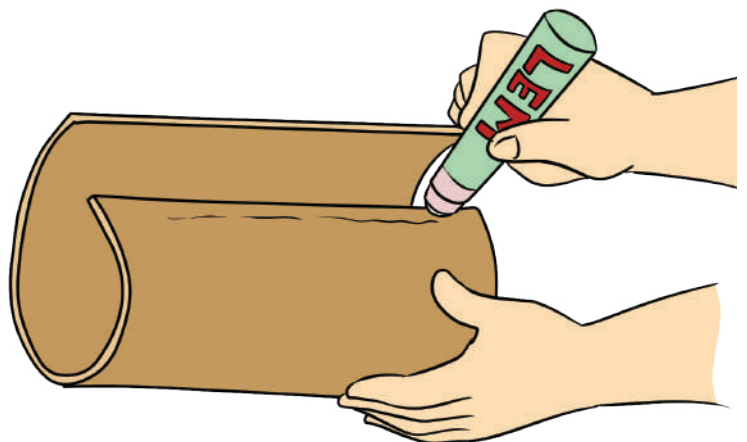
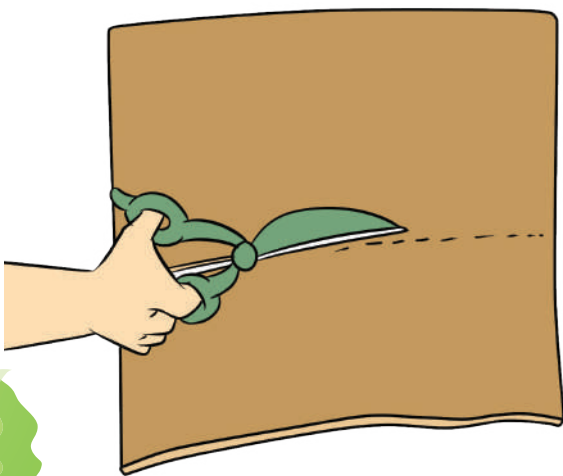



4. Gunting kardus berbentuk lingkaran.
5. Kemudian, buat atap kerucut dari kardus berbentuk lingkaran.
6. Tempel atap kerucut di atas kardus bentuk tabung.

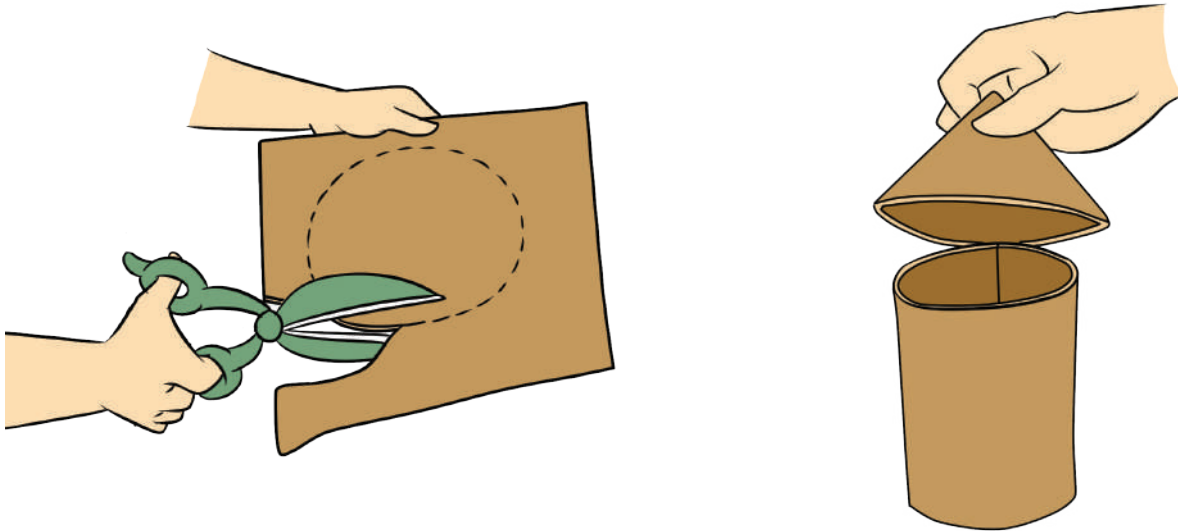

7. Buat rumbai-rumbai dari kertas koran dan tempel di atap rumah.
8. Buat pintu dan jendela dari kertas warna dan tempelkan di dinding rumah Honai.

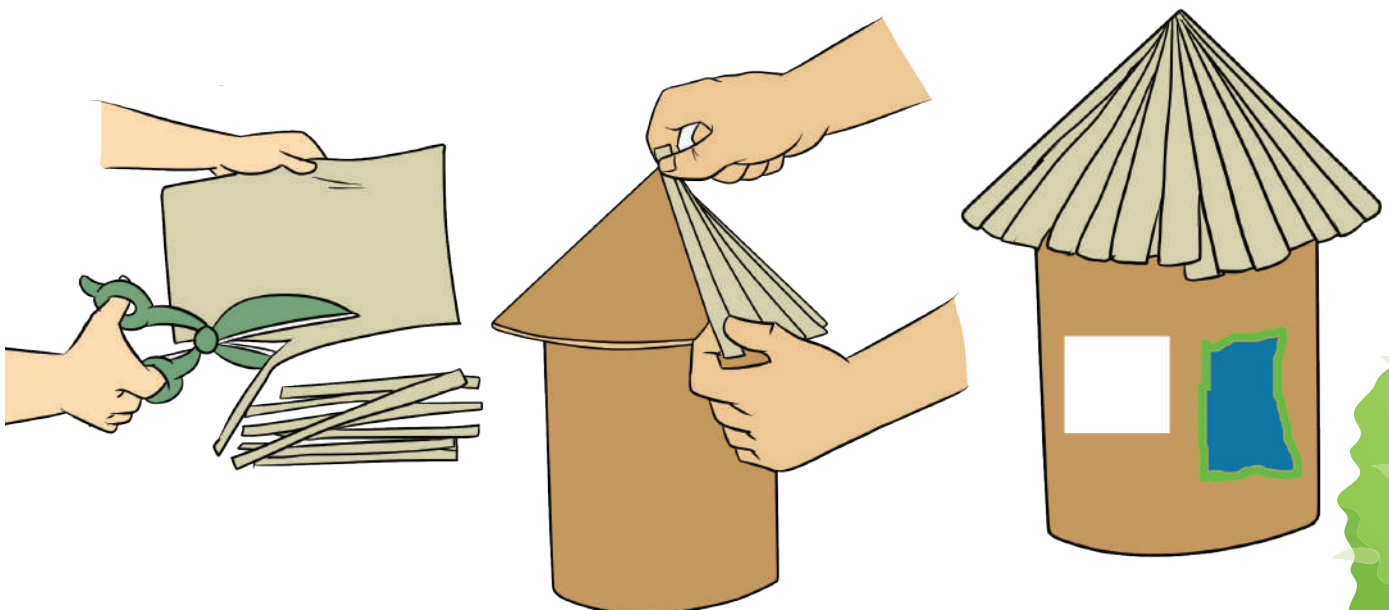



## Menghias Monas

- ✎ Ini adalah tugu Monas.
- ✎ Tugu Monas ada di Jakarta.
- ✎ Tempelkan ampas kelapa di gambar Monas.

### Bahan dan Alat:

- Ampas kelapa
- Pewarna makanan warna coklat dan kuning
- Lem

### Cara Membuat:

- Campurkan sebagian ampas kelapa dengan pewarna makanan warna coklat.
- Campurkan sisa ampas kelapa dengan pewarna makanan warna kuning.
- Keringkan ampas kelapa yang telah dicampur pewarna makanan.
- Tempelkan ampas kelapa warna coklat pada gambar tiang Monas dan ampas kelapa warna kuning pada gambar api Monas.



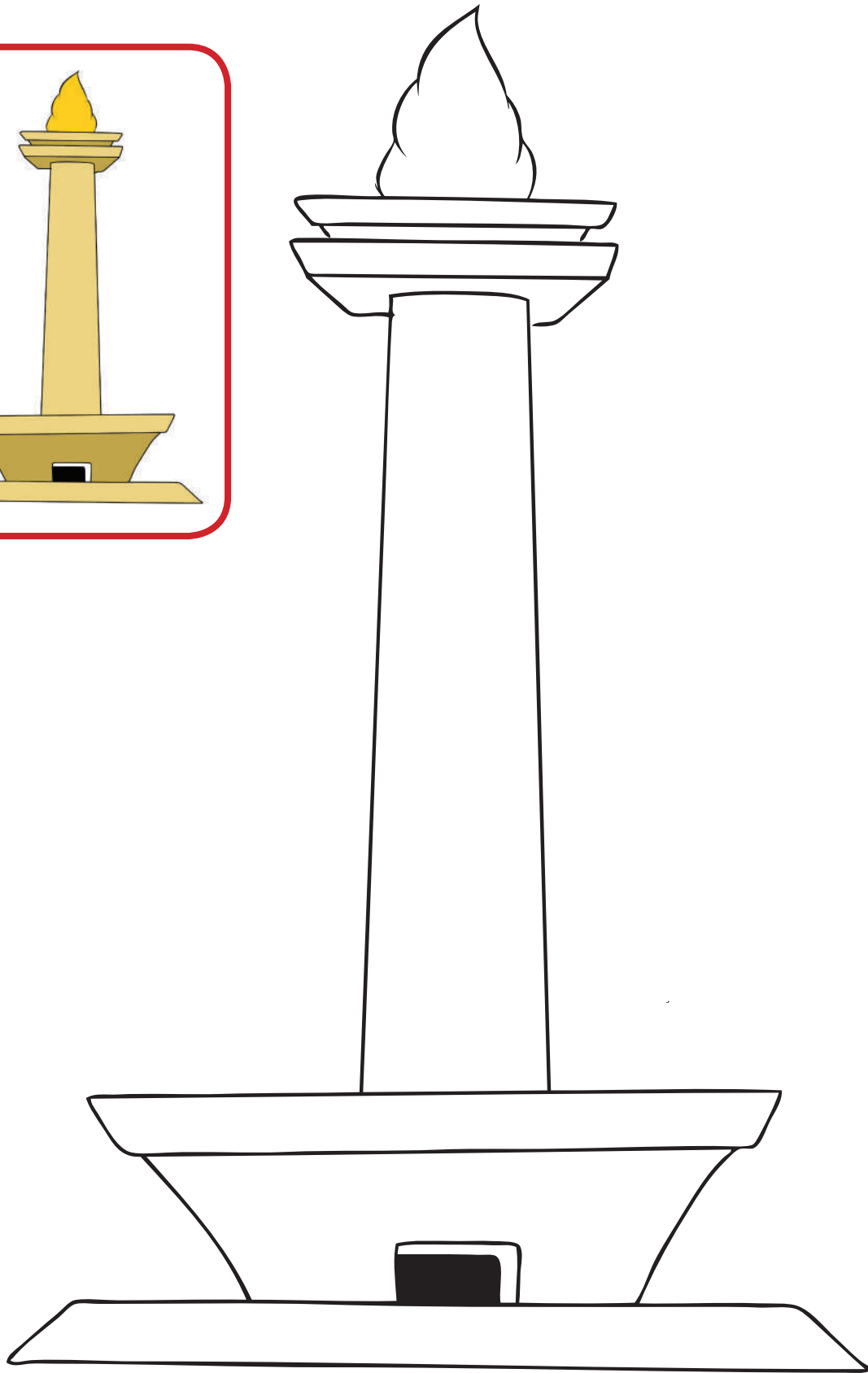
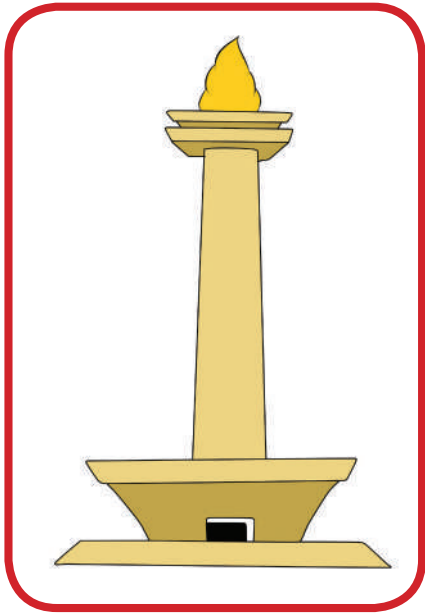



## Kecil-Besar

-  Gunting gambar Monas pada halaman 29.
-  Tempelkan gambar Monas dari ukuran kecil sampai besar.

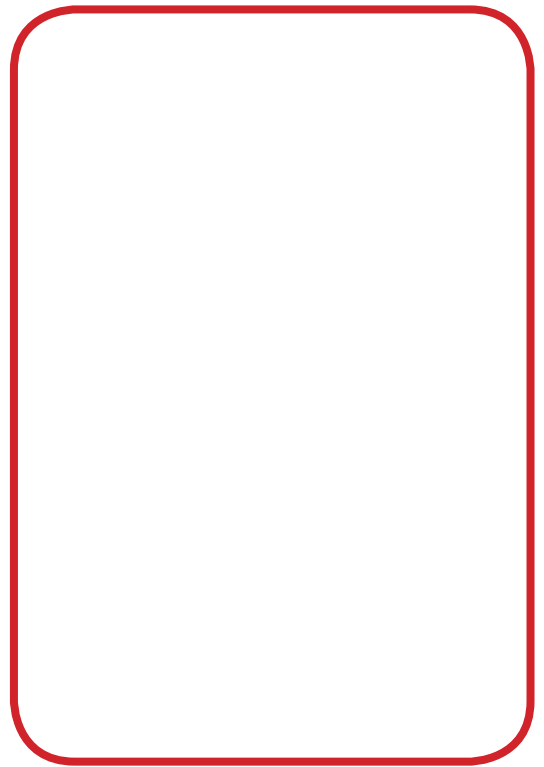
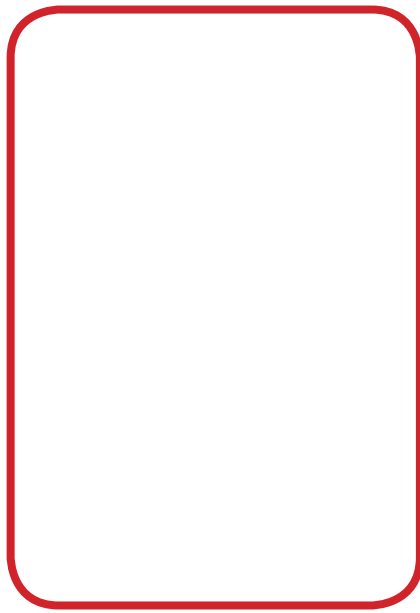
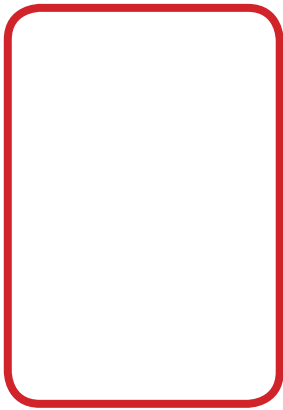



## Menunjukkan Jalan

- ✎ Boni pergi ke pantai.
- ✎ Fira pergi ke rumah adat Minangkabau.
- ✎ Bantu Boni dan Fira menunjukkan jalannya.

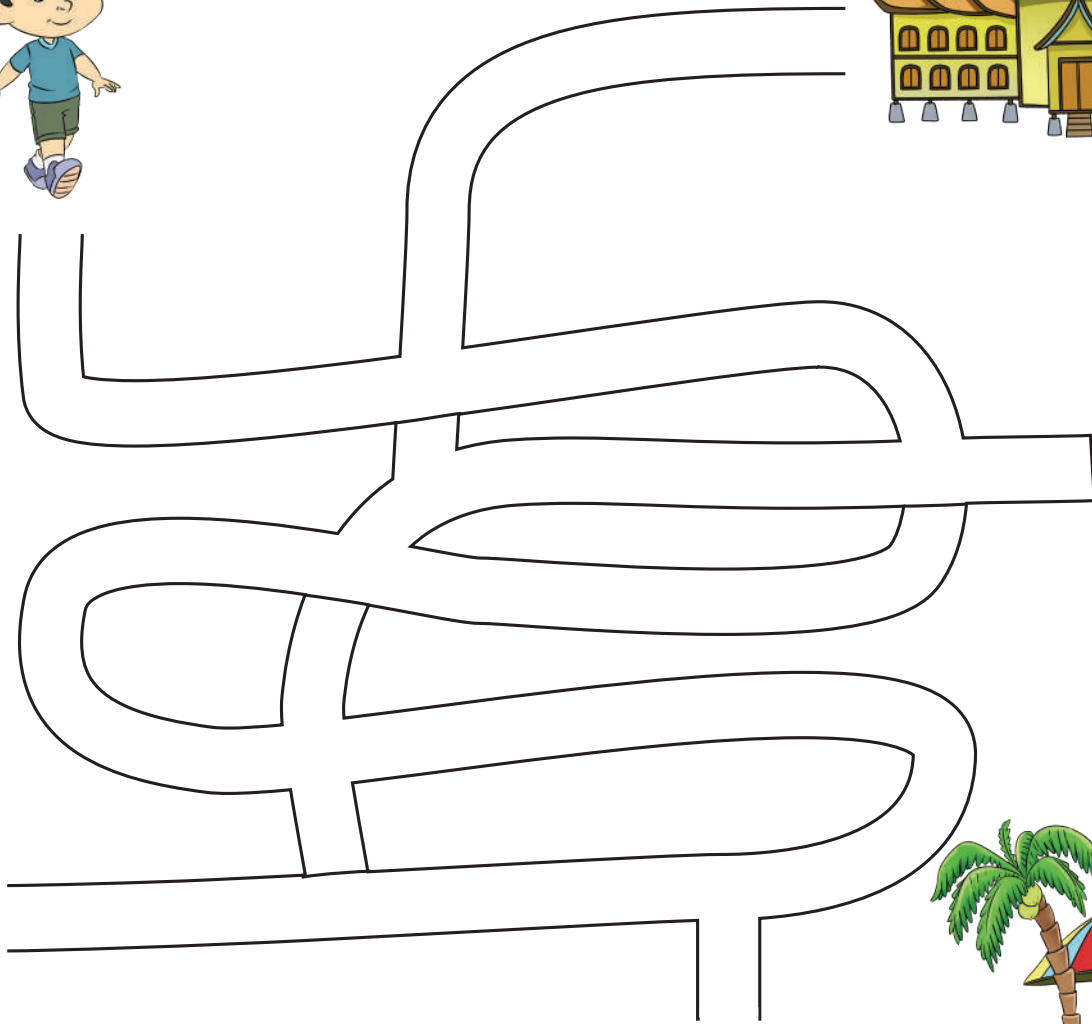

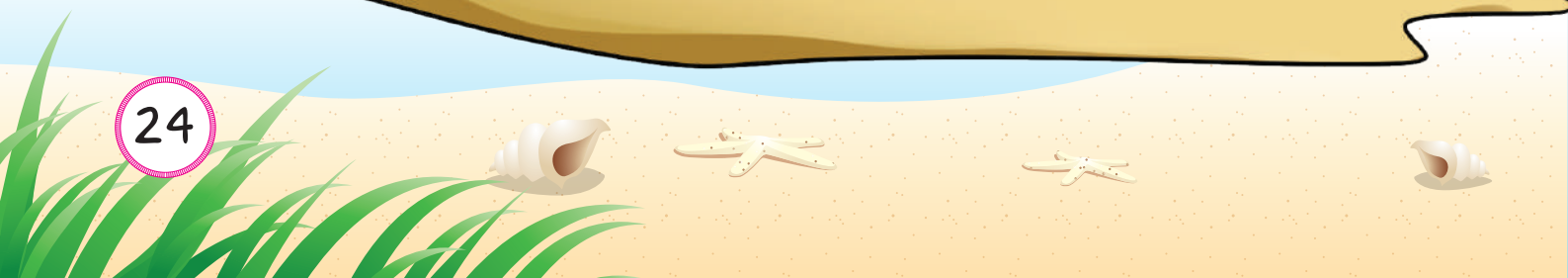

# Tips Menjadi Anak Indonesia

1. Melaksanakan upacara bendera dengan khidmat.
2. Menyanyikan lagu wajib nasional.
3. Toleransi beragama.
4. Bermain dengan teman dari berbagai suku.
5. Saling menghargai sesama teman.
6. Membacakan buku cerita rakyat nusantara.
7. Meningkatkan kreativitas dengan membuat karya seni sesuai daerahnya.



# Pelaku Perbukuan

## Penulis

**Dede Abdurohman** mengawali kariernya di penerbitan sebagai editor. Sekarang, ia bekerja sebagai editor dan penulis di salah satu penerbit. Ia dapat dihubungi di email: [dede\\_abah@yahoo.co.id](mailto:dede_abah@yahoo.co.id) atau FB: Dede Aman Ragil.

## Ilustrator

**Pandu Dharma** mulai mengawali kariernya sebagai ilustrator lepas pada tahun 2000-an hingga sekarang. Ia dapat dihubungi di email: [pandudharma1980@gmail.com](mailto:pandudharma1980@gmail.com).

## Penelaah

**Renni Kusnaeni, M.Pd.**, Ketua IGTKI Provinsi Jawa Barat. Lulusan dari Universitas Islam Nusantara ini dapat dihubungi di email: [rennikusnaeni@gmail.com](mailto:rennikusnaeni@gmail.com)

**Dr. Soraya, M.Hum.**, Dosen dan Peneliti Bahasa Inggris dari STBA LIA Jakarta. Lulusan dari Program Magister Linguistik Universitas Indonesia dan Doktor pada Program S3 Pendidikan Bahasa di Universitas Negeri Jakarta ini dapat dihubungi di email: [dear\\_soraya@yahoo.com](mailto:dear_soraya@yahoo.com).

**Ratih Zulhaqqi, M.Psi.**, Psikolog Anak Klinik Terpadu Fakultas Psikologi Universitas Indonesia. Lulusan dari Program Magister Profesi Klinis Anak Universitas Indonesia ini dapat dihubungi di email: [ratih.zulhaqqi@gmail.com](mailto:ratih.zulhaqqi@gmail.com).

# Lembar Gunting Tempel

Halaman 5

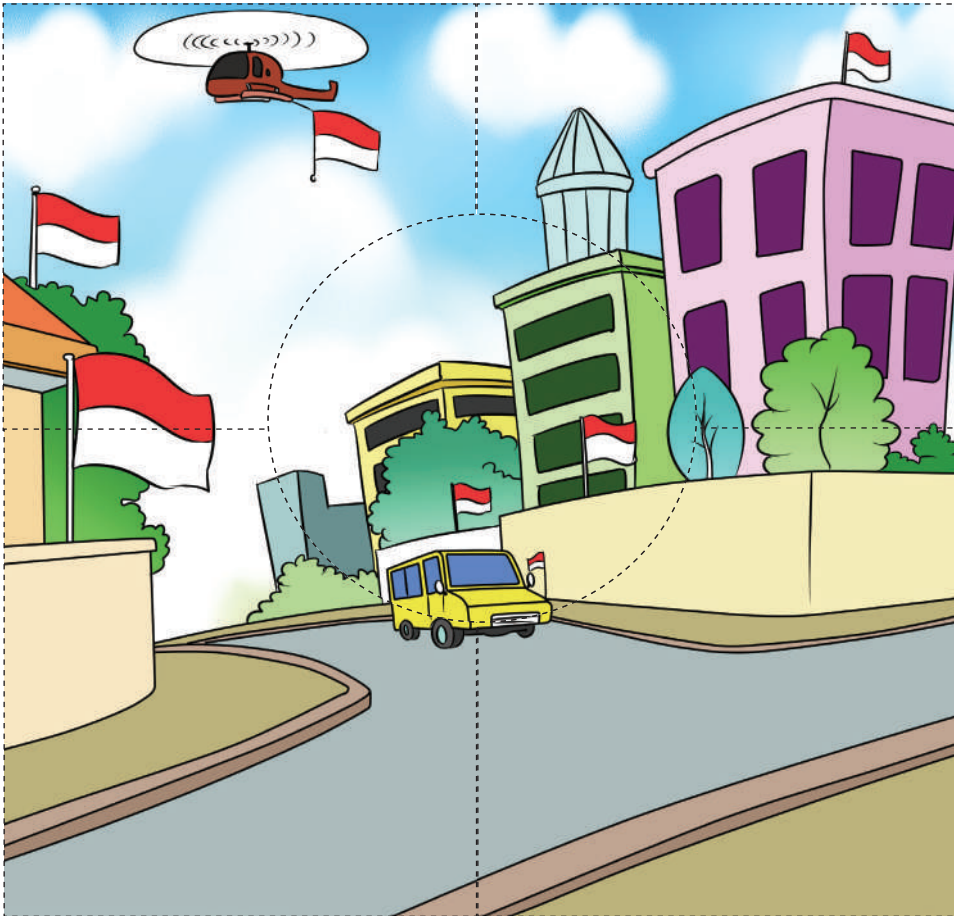

Halaman 14



Halaman 22

